

Autonics PANEL METER MT4N SERIES INSTRUCTION MANUAL



Thank you for choosing our Autonics products. Please read the following safety considerations before use.

Safety Considerations

- Please observe all safety considerations for safe and proper product operation to avoid hazards.
 - Warning: Failure to follow these instructions may result in personal injury or death.
 - Caution: Failure to follow these instructions may result in personal injury or product damage.
 - Warning: Failure to follow this instruction may result in fire or electric shock.
- Fail-safe device must be installed when using the unit with machinery that may cause serious injury or substantial economic loss.
 - Do not use the unit in the place where flammable/explosive/corrosive gas, high humidity, direct sunlight, radiant heat, vibration, impact, or salinity may be present.
 - Install on a device panel to use.
 - Do not connect, repair, or inspect the unit while connected to a power source.
 - Check 'Connections' before wiring.
 - Do not disassemble or modify the unit.

Ordering Information

MT	4	N	-	DV	-	E	N
----	---	---	---	----	---	---	---

Control output: 0, 1, 2, 3, 4, 5
Power supply: E
Input: DV, DA, AV, AA
Size: N
Digit: 4
Item: MT

Front Panel Identification

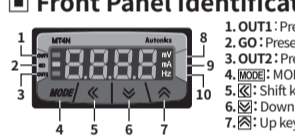

Panel Cut-Out

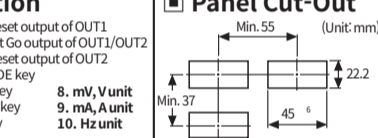

Connections

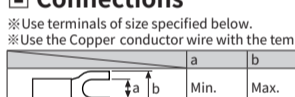

Current Output (DC4-20mA) Scale Adjustment Function

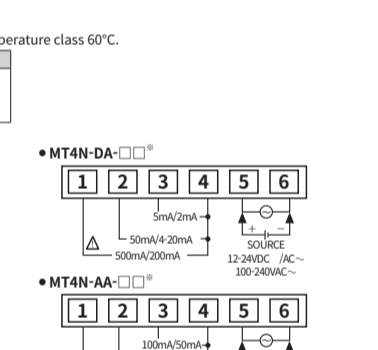

AC Frequency Measurement Function

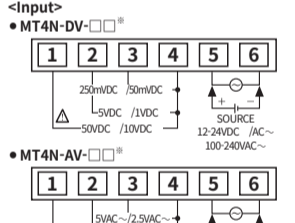

Error Correction Function

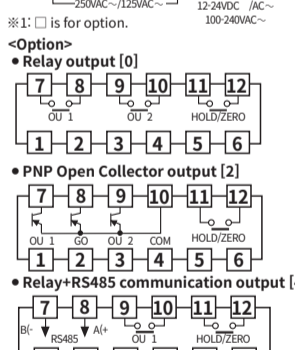

Zero Adjustment Function

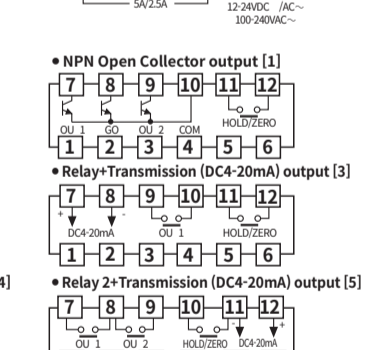

Gradient Correction Function

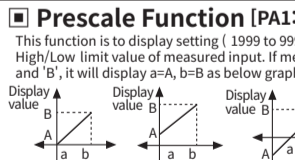

Preset Output Mode

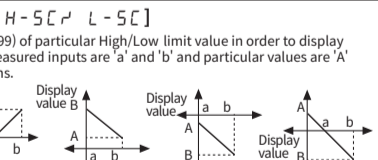

Error Display Function

Display	Description
HHHH	Flashes when measured input is exceeded the max. allowable input (110%)
LLLL	Flashes when measured input is exceeded the min. allowable input (10%)
d-LH	Flashes when display input is exceeded H SC setting value
d-LL	Flashes when display input is exceeded L SC setting value
F-HH	Turns ON when input frequency is exceeded the max. display value of measured range
oUr	Flashes when it exceeds zero range (±99)

Initialization Function

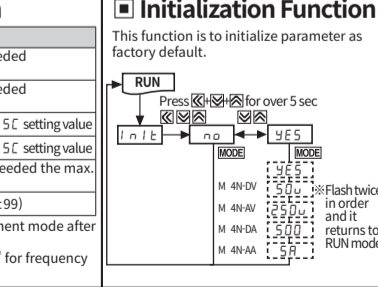

Display Cycle Delay Function

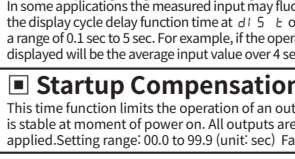

Startup Compensation Timer Function

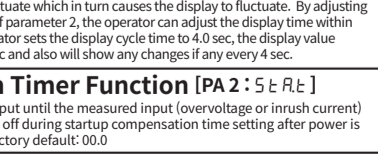

User Manual For Communication

The above specifications are subject to change and some models may be discontinued without notice. Be sure to follow cautions written in the instruction manual and the technical descriptions (catalog, homepage).

Specifications

Model	MT4N DV □ □ MT4N DA □ □	MT4N AV □ □ MT4N AA □ □	MT4N DV □ □ MT4N DA □ □	MT4N AV □ □ MT4N AA □ □
Measurement input	DC voltage, ampere	AC voltage, ampere, Frequency	DC voltage, ampere	AC voltage, ampere, Frequency
Power supply	12 24VDC , 12 24VAC	100 240VAC	12 24VDC , 12 24VAC	100 240VAC
Allowable voltage range	90 to 110%	90 to 110%	90 to 110%	90 to 110%
Power consumption	DC: 3W, AC: 5VA For MT4N □ □ □ □	DC: 5W, AC: 8VA	5VA	5VA
Display method	7 Segment LCD display (Character height: 9mm)			
Display accuracy	23°C ± 5°C DC Type: F.S. ± 0.1% rdg ± 2digit / AC Type: F.S. ± 0.3% rdg ± 3digit 10°C to 50°C DC/AC Type: Within F.S. ± 0.3% rdg ± 3digit only for Current 5A terminal			
Max. allowable input	110% F.S. for each measured input range			
A/D conversion method	Δ (Sigma Delta) ADC			
Sampling cycle	DC type: 50ms, AC type: 16.6ms			
Max. display range	1999 to 9999 (4digit)			
Preset output	Relay output: Contact capacity: 125VAC 0.3A, 30VDC 1A/Contact composition: N/O (1a) NPN/PNP Open Collector output: 12 24VDC ± 2V 50mA Max. (Load resistance)			
Sub output (Transmission output)	RS485 communication output: Baud rate: 1200/2400/4800/9600, Communication method: 2 wire half duplex, Synchronous method: Sub synchronization, Protocol: Modbus type DC4 20mA output: Resolution: 12,000 division (Load resistance max. 600Ω)			
Insulation resistance	Over 20MΩ (at 500VDC megger)			
Dielectric strength	1000VAC for 1 minute (Between external terminal and case)		2000VAC for 1 minute (Between external terminal and case)	
Noise immunity	± 2kV the square wave noise (pulse width: 1μs) by the noise simulator			
Vibration	Mechanical: 0.75mm amplitude at frequency of 10 to 55Hz (for 1 min) in each X, Y, Z direction for 2 hours Malfunction: 0.5mm amplitude at frequency of 10 to 55Hz (for 1 min) in each X, Y, Z direction for 10 minutes			
Shock	Mechanical: 100m/s ² (Approx. 10G) in each X, Y, Z direction for 3 times Malfunction: 300m/s ² (Approx. 30G) in each X, Y, Z direction for 3 times			
Environment	Ambient temperature: 10 to 50°C, Storage: 20 to 60°C Ambient humidity: 35 to 85%RH, Storage: 35 to 85%RH			
Insulation type	Double insulation or reinforced insulation (Mark: □), Dielectric strength between the measuring input part and the power part: 1kV			
Approval	CE			
Weight	Approx. 127g (approx. 64g)			

※1: The weight includes packaging. The weight in parenthesis is for unit only.
※Environment resistance is rated at no freezing or condensation.

Measurement Input [PA1: Input]

Type	Measured input and range	Input impedance	Display range [Standard]	Prescale Display range [Standard]
DC Volt	0.50V [50V]	433.48kΩ	0.00 to 50.00 (fixed)	0.00 to 50.00 (fixed)
	1.0V [10V]	433.48kΩ	0.00 to 10.00 (fixed)	0.00 to 10.00 (fixed)
	5.0V [5V]	43.48kΩ	0.00 to 5.00 (fixed)	0.00 to 5.00 (fixed)
	1.0V [1V]	43.48kΩ	0.00 to 1.00 (fixed)	0.00 to 1.00 (fixed)
	0.250mV [250mV]	2.28kΩ	0.0 to 250.0 (fixed)	0.0 to 250.0 (fixed)
DC Ampere	0.50mA [500mA]	0.220Ω	0.0 to 500.0 (fixed)	0.0 to 500.0 (fixed)
	2.00mA [200mA]	0.220Ω	0.0 to 200.0 (fixed)	0.0 to 200.0 (fixed)
	0.50mA [50mA]	2.0Ω	0.00 to 50.00 (fixed)	0.00 to 50.00 (fixed)
	4.20mA [42mA]	2.0Ω	4.00 to 20.00 (fixed)	4.00 to 20.00 (fixed)
	0.5mA [5mA]	20Ω	0.000 to 5.000 (fixed)	0.000 to 5.000 (fixed)
AC Volt	0.250V [250V]	1.086MΩ	0.0 to 250.0 (fixed)	0.0 to 250.0 (fixed)
	0.125V [125V]	1.086MΩ	0.0 to 125.0 (fixed)	0.0 to 125.0 (fixed)
	0.50V [50V]	199.12kΩ	0.00 to 50.00 (fixed)	0.00 to 50.00 (fixed)
	0.25V [25V]	199.12kΩ	0.00 to 25.00 (fixed)	0.00 to 25.00 (fixed)
	0.5V [5V]	19.12kΩ	0.000 to 5.000 (fixed)	0.000 to 5.000 (fixed)
AC Ampere	0.25A [25A]	0.01Ω	0.000 to 2.500 (fixed)	0.000 to 2.500 (fixed)
	0.5A [5A]	0.01Ω	0.000 to 5.000 (fixed)	0.000 to 5.000 (fixed)
	0.25A [25A]	0.01Ω	0.000 to 2.500 (fixed)	0.000 to 2.500 (fixed)
	0.500mA [500mA]	0.180Ω	0.0 to 500.0 (fixed)	0.0 to 500.0 (fixed)
	0.250mA [250mA]	0.180Ω	0.0 to 250.0 (fixed)	0.0 to 250.0 (fixed)

※Connect to the input terminals whose 30% to 100% of the input range includes the max. value of the input range to measure. When the max. input value is under the 30% of the input terminal range, display accuracy is degraded. When the max. input value is over the 100%, it may result in input terminal damage.

※When "HHHH" or "LLLL" flashes with a certain measurement input, disconnect power supply and then check the cables.

Monitoring Max./Min. Display Value Function

It monitors max./min. value of display value based on the current displays value and then displays the data at HPEL, LPEL of parameter 0. Set the delay time (0 to 30 sec) at PEL of parameter 2 in order to prevent malfunction caused by initial overcurrent or overvoltage, when monitoring the peak value. Delay time is 0 to 30 sec and it starts to monitor the peak value after the set time. When pressing any one of HPEL, LPEL of parameter 0, the monitored data is initialized.

Current Output (DC4-20mA) Scale Adjustment Function

It sets current output for the display value at the output current DC 4 20mA. It sets display value for 4mA at F5-L and 20mA at F5-H and the range between F5-H and F5-L should be 10% F.S. (When this set as under 10% F.S., it changed as over 10% F.S. automatically.) Preset display value is fixed to output as 4mA at under F5-L and 20mA at over F5-H.

AC Frequency Measurement Function

It measures input signal frequency when it is AC input. It uses fixed decimal point [PA1: dot], measured range can be changed by setting and measured range of decimal point position is as below chart. It is available to adjust the upper gradient at [PA1: Index] and [PA1: Index]. In order to measure frequency normally, input signal, over 10% F.S. of the measured range, should be supplied. Please select the proper point of measurement terminal.

Error Correction Function

It corrects display value error of measured input. It corrects display value error of measured input. It corrects display value error of measured input. It corrects display value error of measured input.

Zero Adjustment Function

It adjusts the zero value of the optional configured input value as zero by force, zero point error can be adjusted with 3 ways as below. When zero point adjustment with front key and Hold terminal is finished normally, zero point of measurement terminal is displayed and the adjusted value at saved in InbL automatically.

Gradient Correction Function

It corrects the gradient of prescale value and display value. (Figure 1) Display value Y can be adjusted as α, β times against X input value by correction function [InbH] and used as correction function of max. display value [HSC]. Adjustment range is 0.100 to 5.000 and multiply current gradient.

Parameter

Parameter	Display	Function	Note
PA1 (Parameter 1)	In	Input type	Selectable RMS/AVG in AC type Available AC type only.
	In r	Input range	Selection of input range
	dI SP	Display	Selection of display type
	Stnd	Standard	Standard scale range
	F r E 9	Frequency	Frequency display Available AC type only.
	SCL	Scale	Scale range
	L SC	Low scale	Set max. value of display range
	H SC	High scale	Set min. value of display range
	dot	Dot	Set decimal point position
	d Unit	Display unit lamp	Set display unit
	InbH	Input bias high	Correct High limit gradient of display value
	InbL	Input bias low	Correct Low limit gradient of display value
	InbE	Input bias exponent	Set display index of frequency mode
	ou1 t	Out1 type	Select output mode of OUT1
	ou2 t	Out2 type	Select output mode of OUT2
PA2 (Parameter 2)	HYS	Out1 hysteresis	Select hysteresis of OUT1
	HYS2	Out2 hysteresis	Select hysteresis of OUT2
	StRt	Startup compensation time	Set startup compensation time
	PEL	Peak time	Set monitoring delay time for peak value (sec)
	dI St	Display time	Set sampling time (sec)
	CoLr	Color	Select color
	ZEro	Zero key	Set usage of front side zero adjustment key
	EvIn	Event input	Set external terminal (,) function
	FS H	Full scale high	Set High limit value output position of PV output
	FS L	Full scale low	Set Low limit value output position of PV output
	AdrS	Address	Set communication address
	bPS	Bit per second	Set baud rate (bps)
	PrbY	Parity bit	Set parity bit
	StpB	Stop bit	Set stop bit
	rSWt	Response waiting time	Set response waiting time
LoC	Lock	Enable lock status	
PA0 (Parameter 0)	ou1 H	Out1 high preset	Set value of OUT1 High limit output
	ou1 L	Out1 low preset	Set value of OUT1 Low limit output
	ou2 H	Out2 high preset	Set value of OUT2 High limit output
	ou2 L	Out2 low preset	Set value of OUT2 Low limit output
	HPeak	High peak	Max. value by data monitoring
LPeak	Low peak	Min. value by data monitoring	

Parameter Setting

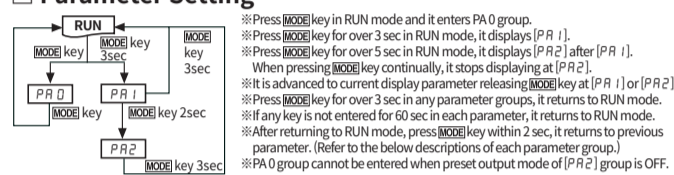

Change The Parameter Setting Value

- Advance to the parameter to be changed when pressing MODE key continuously in RUN mode and releasing MODE key at the parameter. (Refer to "Parameter Setting".)
- When pressing MODE key in each parameter, the initial mode of the parameter is displayed. (Refer to the description of each parameter.)
- When pressing one of HPEL, LPEL keys in display mode, the saved setting value is displayed.
- Change the setting value by HPEL or LPEL key when setting value flashes.
- When confirming the setting value with MODE key, the changed setting value flashes twice and enters into the next setting.
- It returns RUN mode from parameter by pressing MODE key for 3 sec.

Parameter 0

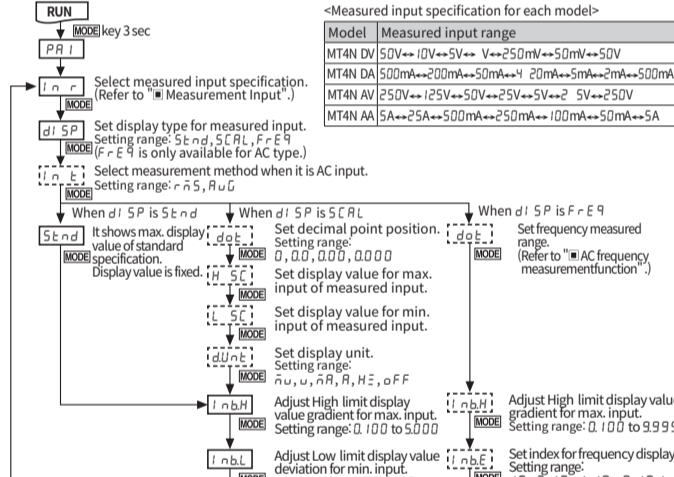

Parameter 1

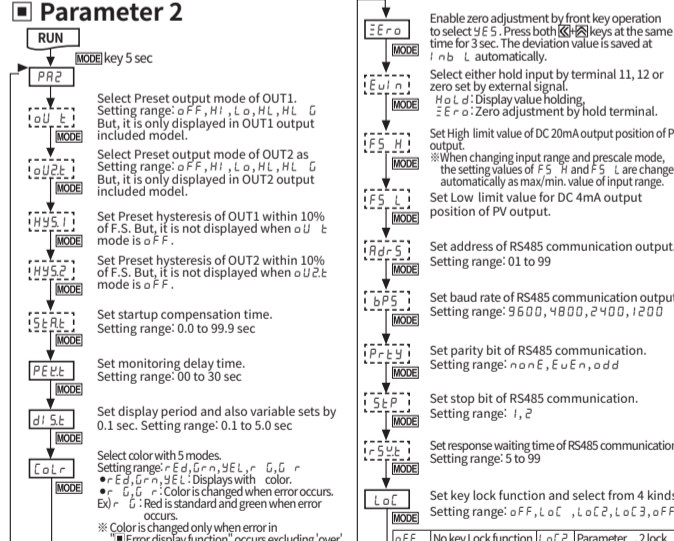

Parameter 2

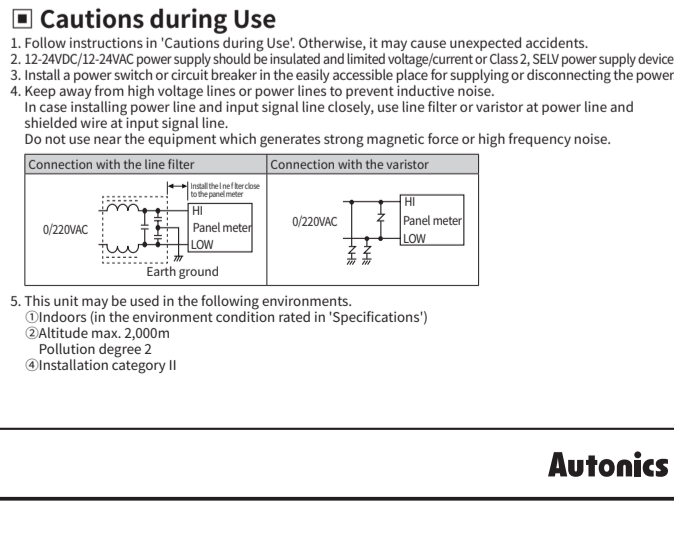

Cautions during Use

- Follow instructions in 'Cautions during Use'. Otherwise, it may cause unexpected accidents.
- 12-24VDC/12-24VAC power supply should be insulated and limited voltage/current or Class 2, SELV power supply device.
- Install a power switch or circuit breaker in the easily accessible place for supplying or disconnecting the power.
- Keep away from high voltage lines or power lines to prevent inductive noise.
- In case installing power line and input signal line closely, use line filter or varistor at power line and shielded wire at input signal line.
- Do not use near the equipment which generates strong magnetic force or high frequency noise.

- This unit can be used in the following environments.
 - Indoors (in the environment condition rated in 'Specifications')
 - Altitude max. 2,000m
 - Pollution degree 2
 - Installation category II